

Clarke®



4½" (115mm) ANGLE GRINDER

MODEL NO: CAG800B

PART NO: 6472010

OPERATING & MAINTENANCE INSTRUCTIONS



UK
CA | CE

ORIGINAL INSTRUCTIONS

GC11/22 - Rev 4

INTRODUCTION

Thank you for purchasing this CLARKE Angle Grinder.

Before attempting to use this product, please read this manual thoroughly and follow the instructions carefully. In doing so you will ensure the safety of yourself and that of others around you, and you can look forward to your purchase giving you long and satisfactory service.

Your Angle Grinder has been designed to give long and trouble free service. If, however, having followed the instructions in this booklet carefully, you encounter problems, take the unit to your local CLARKE dealer.

CONTENTS

| | |
|---------------------------|---|
| 1 x Angle Grinder | 1 x Pair of Disc Retaining Flanges (fitted) |
| 1 x Auxiliary Handle | 115mm Grinding Disc |
| 1 x Pin Spanner | 1 x Open Grinding Disc Guard |
| Pair Spare Carbon Brushes | 1 x Closed Cutting Disc Guard |

GUARANTEE

This product is guaranteed against faulty manufacture for a period of 12 months from the date of purchase. Please keep your receipt which will be required as proof of purchase.

This guarantee is invalid if the product is found to have been abused or tampered with in any way, or not used for the purpose for which it was intended.

Faulty goods should be returned to their place of purchase, no product can be returned to us without prior permission.

This guarantee does not effect your statutory rights.

ENVIRONMENTAL RECYCLING POLICY



Through purchase of this product, the customer is taking on the obligation to deal with the WEEE in accordance with the WEEE regulations in relation to the treatment, recycling & recovery and environmentally sound disposal of the WEEE.

In effect, this means that this product must not be disposed of with general household waste. It must be disposed of according to the laws governing Waste Electrical and Electronic Equipment (WEEE) at a recognised disposal facility.

SAFETY SYMBOLS

The following safety symbols may be found on the machine.



Wear ear protection



Wear eye protection



Not suitable for wet grinding



Read instruction manual before use



Wear hand protection

GENERAL SAFETY RULES



CAUTION: FAILURE TO FOLLOW THESE PRECAUTIONS COULD RESULT IN PERSONAL INJURY, AND/OR DAMAGE TO PROPERTY.

WORK ENVIRONMENT

1. **Keep the work area clean and well lit.** Cluttered and dark areas invite accidents.
2. **Do not operate power tools in explosive atmospheres, such as in the presence of flammable liquids, gases or dust.** Power tools create sparks which may ignite the dust or fumes.
3. **Keep children and bystanders away while operating a power tool. Anyone entering the work area must wear personal protective equipment.** Distractions can cause you to lose control and fragments of work or a broken disc may fly away and cause injury.
4. **Store power tools properly when not in use.** Abrasive products should be stored in a dry, secure place out of the reach of children

ELECTRICAL SAFETY

1. **Power tool plugs must match the outlet. Never modify the plug in any way. Do not use adapter plugs with earthed (grounded) power tools.** Unmodified plugs and matching outlets will reduce the risk of electric shock.
2. **Do not expose power tools to rain or wet conditions or use discs that require liquid lubricants.** Water entering a power tool will increase the risk of electric shock.
3. **Do not abuse the power cable. Never use the cable for carrying, pulling or unplugging the power tool. Keep the cable away from heat, oil, sharp edges or moving parts.** Damaged or entangled cables increase the risk of electric shock.
4. **When operating a power tool outdoors, use an extension cable suitable for outdoor use.** Use of a cable suitable for outdoor use reduces the risk of electric shock.

PERSONAL SAFETY

1. **Stay alert, watch what you are doing and use common sense when operating a power tool.** Do not use a power tool while you are tired or under the influence of drugs, alcohol or medication. A moment of inattention while operating power tools may result in personal injury.

2. **Use personal protective equipment.** Always wear eye protection. Safety equipment such as dust mask, non-skid safety shoes, hearing protection and a workshop apron capable of stopping small abrasive or workpiece fragments.
3. **Avoid accidental starting.** Ensure the switch is in the off position before plugging in. Carrying power tools with your finger on the switch or plugging in power tools that have the switch on invites accidents.
4. **Remove any adjusting key or wrench before turning the power tool on.** A wrench or a key left attached to a rotating part of the power tool may result in personal injury.
5. **Do not overreach.** Keep proper footing and balance at all times. This enables better control of the power tool in unexpected situations. **Dress properly.** Do not wear loose clothing or jewellery.
6. Keep your hair, clothing and gloves away from moving parts. Loose clothes, jewellery or long hair can be caught in moving parts. Keep the work area clean and tidy.
7. This tool vibrates with use. Vibration may be harmful to your hands or arms. Stop using the tool if discomfort, a tingling feeling or pain occurs. Seek medical advice before resuming use.
8. **Hold the power tool by insulated gripping surfaces only, when performing an operation where the cutting tool could contact hidden wiring or its own cable.** Contacting a live wire may make exposed parts of the power tool live and give the operator an electric shock.
9. **Never lay a power tool down until it has come to a complete standstill.** The rotating accessory may grab the surface and pull the tool out of your control.
10. Do not run the power tool while carrying it at your side. Accidental contact with a spinning accessory could snag on clothing and pull the tool to your body.
11. Regularly clean the power tool's air vents. The motor fan will draw dust inside the housing and accumulation of material could cause electrical hazards.
12. **Avoid operator fatigue.** Stop the power tool at regular intervals for a short break to rest hands and arms.
13. **Maintain your tools.** Keep all handles and grips dry and clean.

ANGLE GRINDER SAFETY INSTRUCTIONS

1. **Before starting work, always consider the following:** The use of hand held angle grinders for grinding and cutting operations can present risks to the user. Full observation of the safety instructions in this user guide is essential.
2. **Before undertaking grinding or cutting operations, always consider the following:** Is the grinding/cutting work necessary? Could a different tool be used with less risk? (e.g. a fixed controlled cutting/grinding machine). Can the work be sensibly positioned, secured and accessed so the operator can maintain adequate control of the tool, taking into account, for example the possible hazards associated with potential snatch/jamming of a cutting disc. Is the cutting task too large for a hand held tool? If in doubt, use an alternative lower risk solution or refer to qualified trade personnel.
3. **Always use the correct tool for the job.** Always assess the job. You should never force a small angle grinder to do the job of a heavy tool. Do not use tools for purposes not intended.
4. **Always position the power cable clear of the spinning disc.** If you lose control, the cable may be cut or snagged and you hand drawn onto the spinning disc.
5. **Start up speed.** Always allow the angle grinder to run up to full operating speed before applying it to the job.
6. **Applying the disc to the workpiece.** Never bump the angle grinder disc on the workpiece, or let the disc hit any other objects while grinding.
7. **Do not abuse the mains lead.** Never carry the tool by the mains lead or pull it to disconnect it from the mains socket. Keep the mains lead away from heat, oil and sharp edges.
8. **Secure the work.** Use clamps, or vices to hold the workpiece. Failure to secure the workpiece could result in serious injury.
9. **Remove adjusting keys and wrenches.** Form the habit of checking to see that keys and adjusting wrenches are removed from the tool before turning it on.
10. **Use outdoor extension leads.** When the tool is used outdoors, only use extension leads intended for outdoor use. Always make sure that the extension lead is correctly rated.
11. **Check damaged parts.** A guard or other parts that are damaged should be properly repaired or replaced, by an authorised service centre, unless otherwise indicated in this user guide. Have defective switches replaced by an authorised service facility.

12. **Accessories. Only use the recommended accessories.** Ensure that the wheels and discs are fitted in accordance with the manufacturer's instructions.
13. **Only use discs that comply with EN12413 or EN13236.** Make sure that the disc used is suitable for the no load speed of the angle grinder. See Specifications on page 16. Check that the speed marked on the wheel dimensions are compatible with the grinder. Check that discs are specifically for hand held angle grinder use.
14. **Sparks and particles.** Ensure that sparks and particles resulting from use do not create a hazard, Use screens where appropriate.
15. **Personal protective equipment.** Always use protective safety glasses and hearing protectors. Use other protective equipment such as gloves, apron and helmet where necessary. If working at floor level, always wear knee pads.
16. **Switching off.** The disc will continue to rotate for a few seconds after the angle grinder is switched off. Always wait until the disc has completely stopped before putting the angle grinder down.
17. **Use the disc guard.** Do not use the angle grinder without the disc guard. Make sure that the guard is securely fitted and positioned for maximum safety before operating the angle grinder. Always use the correct guard for cutting or grinding work as described in this manual.
18. **The grinding surface of depressed centre wheels must be mounted below the plane of the guard lip.** An improperly mounted wheel that projects above the plane of the guard lip cannot be adequately protected.
19. **Holding the angle grinder.** Always hold the angle grinder with both hands. Ensure that the workpiece is kept at waist height where possible. Never use the angle grinder between the legs whilst sitting on the floor.
20. **Feed direction.** For cutting, always feed the disc into the work so that an upcutting action is achieved.
21. **Spindle lock.** Do not operate the spindle lock while the spindle is still spinning.
22. Always take care to avoid kickback by maintaining a firm grip of the tool and positioning your body and arm to resist kickback forces. Always use the auxiliary handle for maximum control.
23. Never position your hand close to the rotating parts and take special care when working in corners or with sharp edges, or any situation where the disc could snag.

DISC SAFETY INSTRUCTIONS

1. **Disc speed.** Check the speed of the disc before fitting to your angle grinder. Never use a disc with a rpm speed less than the rpm speed of your angle grinder. See specification on page 18.
2. The outside diameter and thickness of your accessories must be within the capacity rating of the power tool. The correct size accessories can be correctly guarded and controlled.
3. **Inspect the disc before fitting.** Never use a disc that is chipped, cracked or damaged. Fragments from a broken or damaged disc can cause serious injury. Make sure that defective discs are destroyed and not used.
4. **Handling and mounting discs.** Bonded abrasive products are breakable and shall therefore be handled with utmost care. The use of damaged or improperly mounted or used abrasive products is dangerous and can cause serious injuries.
5. **Disc usage.** Always refer to the label for specified usage and observe the safety information. Do not use for purposes other than specified. Discs for wet cutting applications must not be used with this angle grinder.
6. **Use the correct disc.** Always use the correct disc for it's intended task. Using the incorrect disc can cause serious injury.
7. **Using the disc.** Allow the disc and tool to do the work. Never force the disc onto the workpiece as this could cause kickback and/or shatter the disc causing serious injury. Kickback can occur in the event of a disc jam.
8. **Cutting discs.** Do not use cutting discs for side grinding. Do not put sideways pressure on cutting discs.
9. **Do not use reducing bushes.** Do not use separate reducing bushes or adapters to adapt large hole abrasive wheels. Do not force a disc onto a machine or alter the size of the arbor hole.
10. Never use a damaged disc. Inspect each disc before each use for chips, cracks, excess wear. If the tool or accessory is dropped, inspect for damage or install a new accessory. After fitting the accessory, position yourself away from the plane of the rotating accessory and run the tool at full speed. Damaged discs are likely to break apart during this test.
11. **Handling and storing discs.** Abrasive products shall be handled and transported with care. Abrasive products shall be stored in such a manner that they are not subjected to mechanical damage and harmful environmental influences.
12. Always use undamaged mounting flanges that are of the correct size and shape for your cutting or grinding disc. Proper flanges support the disc and reduce the possibility of breakage.

ELECTRICAL CONNECTIONS



WARNING! Read these electrical safety instructions thoroughly before connecting the product to the mains supply.

Before switching the product on, make sure that the voltage of your electricity supply is the same as that indicated on the rating plate. This product is designed to operate on 230VAC 50Hz. Connecting it to any other power source may cause damage.

This product may be fitted with a non-rewireable plug. If it is necessary to change the fuse in the plug, the fuse cover must be refitted. If the fuse cover becomes lost or damaged, the plug must not be used until a suitable replacement is obtained.

If the plug has to be changed because it is not suitable for your socket, or due to damage, it should be cut off and a replacement fitted, following the wiring instructions shown below. The old plug must be disposed of safely, as insertion into a mains socket could cause an electrical hazard.



**WARNING: THE WIRES IN THE POWER CABLE OF THIS PRODUCT ARE COLOURED IN ACCORDANCE WITH THE FOLLOWING CODE:
BLUE = NEUTRAL BROWN = LIVE**

If the colours of the wires in the power cable of this product do not correspond with the markings on the terminals of your plug, proceed as follows.

- The **Blue** wire must be connected to the terminal which is marked **N**.
- The **Brown** wire must be connected to the terminal which is marked **L**.

Plug must be BS1363/A approved.

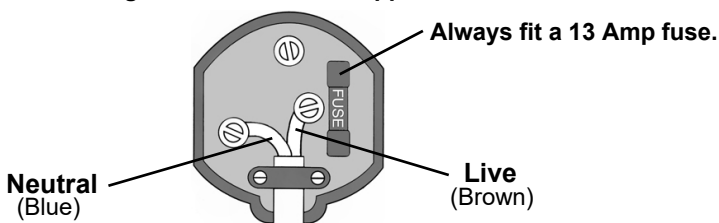

Ensure that the outer sheath of the cable is firmly held by the clamp

We strongly recommend that this machine is connected to the mains supply via a Residual Current Device (RCD)

If in any doubt, consult a qualified electrician. DO NOT attempt any repairs yourself.



This symbol indicates that this is a Class II product, and does not require an earth connection.

OVERVIEW

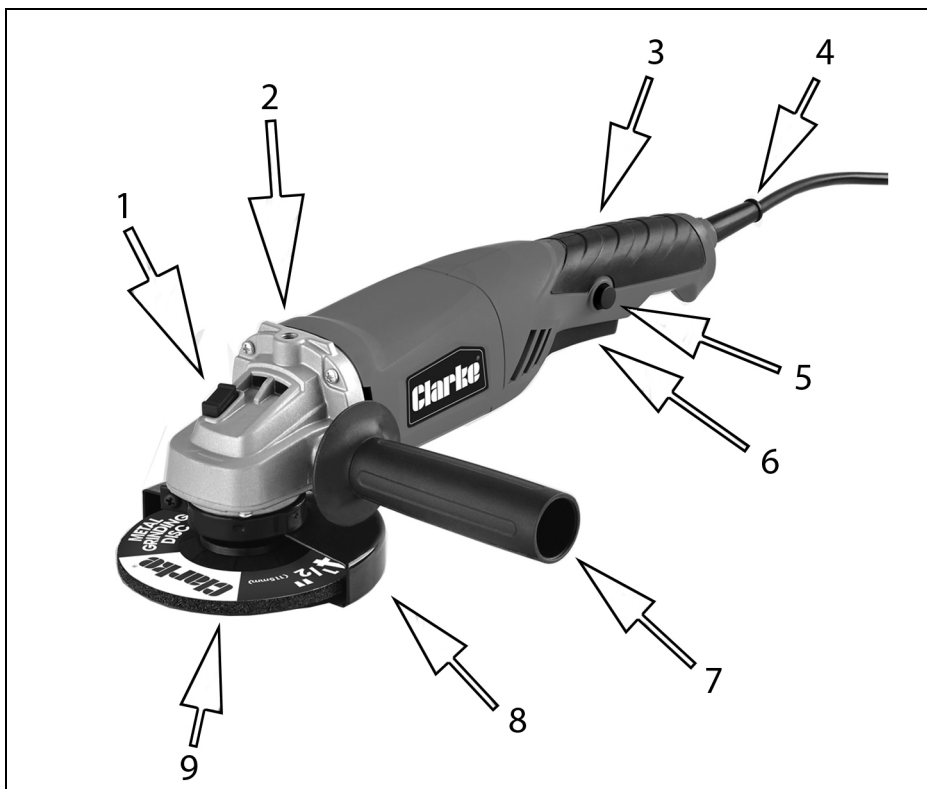

| NO | DESCRIPTION | NO | DESCRIPTION |
|----|----------------------------|----|-----------------------|
| 1 | Spindle Lock Button | 6 | On/Off Trigger Switch |
| 2 | Threaded hole (for handle) | 7 | Auxiliary Handle |
| 3 | Rear Handle | 8 | Grinding Disc Guard |
| 4 | Mains Lead | 9 | Grinding Disc |
| 5 | Trigger Lock Button | | |

BEFORE USE

FITTING / ADJUSTING THE DISC GUARD



WARNING: MAKE SURE THAT THE ANGLE GRINDER IS SWITCHED OFF AND UNPLUGGED FROM THE MAINS SUPPLY BEFORE FITTING OR REMOVING ANY ACCESSORIES.

ENSURE THE CORRECT GUARD IS FITTED FOR EITHER A GRINDING OR A CUTTING DISC, WHICHEVER IS BEING USED.

1. Slide the disc guard into place as shown.

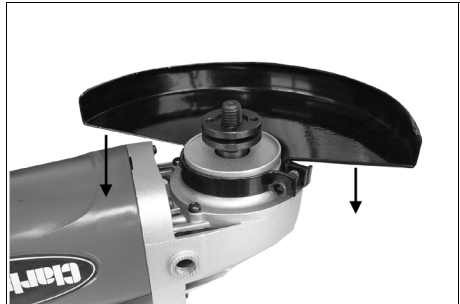

2. Rotate the disc guard to the required position and secure by tightening the screw.



WARNING: THE DISC GUARD SHOULD BE FITTED SO THAT IT PROVIDES MAXIMUM PROTECTION TO THE USER WHEN IN THE WORKING POSITION.

3. Ensure the disc guard is securely fitted before using the grinder.

FITTING AND REMOVING A DISC



WARNING: MAKE SURE THAT THE ANGLE GRINDER IS SWITCHED OFF AND UNPLUGGED FROM THE MAINS SUPPLY BEFORE FITTING OR REMOVING ANY ACCESSORIES.

1. Make sure the disc guard is fitted before you fit any cutting/grinding disc.
2. Press and hold the spindle lock as shown on the right.

NOTE: You may need to turn the spindle by hand to fully engage the spindle lock.

3. Use the pin spanner supplied to remove the outer flange.
4. Make sure that the inner flange is fitted correctly with the raised circular section pointing outwards as shown and the flat section on the opposite side engages with the flat section on the spindle.

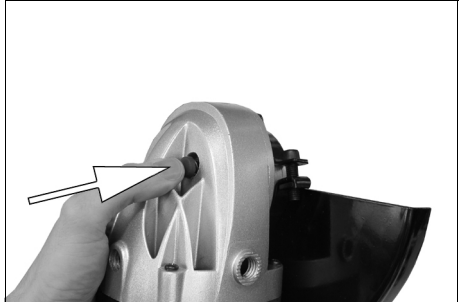

5. Place the grinding disc over the spindle and on top of the inner flange.
 - Place the disc onto the spindle as shown.
 - Make sure that the disc is properly located on the inner flange.

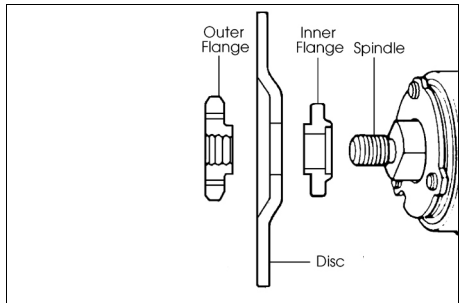

6. Place the outer flange over the spindle.
 - For standard concave discs make sure that the raised section of the outer flange is pointing towards the disc.
 - When using flat discs, the outer flange washer can be reversed so that the raised section is pointing away from the disc.
7. Press and hold the spindle lock and use the pin spanner to tighten the outer flange.

FITTING THE AUXILIARY HANDLE

1. Fit the handle by screwing it into one of the 3 threaded holes on the angle grinder.



USING YOUR ANGLE GRINDER



WARNING: FRAGMENTS FROM A BROKEN/DETACHED DISC CAN CAUSE SERIOUS INJURY.

WARNING: DO NOT STAND DIRECTLY IN LINE WITH THE ROTATING DISC.

WARNING: DO NOT PUT SIDEWAYS PRESSURE ON CUTTING DISCS.

WARNING: ENSURE THAT THE WORKING POSITION ADOPTED DOES NOT CAUSE OPERATOR FATIGUE WHICH MAY LEAD TO LOSS OF CONTROL OF THE DISC AND IMPACT/SNATCH WITH SURROUNDING OBJECTS/MATERIALS.

WARNING: WHEN CUTTING, ENSURE THE INTENDED CUTTING PATH IS CLEAR AND WITH SUFFICIENT CLEARANCE BETWEEN SURROUNDING OBJECTS.

WARNING: WHEN CUTTING, KEEP THE DISC STRAIGHT TO PREVENT SNATCHING OR JAMMING.

WARNING: ALWAYS FIT THE CORRECT GUARD ACCORDING TO WHETHER A CUTTING OR GRINDING DISC IS BEING USED. REFER TO PAGE 14.

THE ON/OFF SWITCH

1. To start the angle grinder, first press and hold the safety button (1) and then squeeze the trigger (2) upwards.

- The disc will start instantly. Always maintain a firm grip with both hands.
- You may damage the angle grinder if you do not press the safety button first.

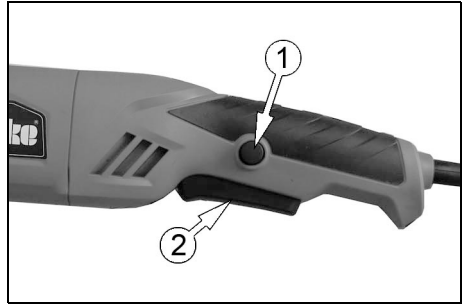

2. To stop the angle grinder, release the trigger.

CUTTING TIPS



WARNING: THE DISC WILL CONTINUE TO ROTATE FOR A FEW SECONDS AFTER THE TRIGGER HAS BEEN RELEASED.

- Do not force the disc through the material. Work with a feed rate that is suited to the material being cut.
- Do not subject the cutting disc to sideways pressure.
- The direction of the cutting motion is important. Always feed the cutting disc into the work so that it cuts in an upward direction. If you do not do this it can result in the disc climbing out of the cut in an uncontrolled manner and may lead to loss of control or serious injury.

GRINDING TIPS



WARNING: WHEN GRINDING, ONLY USE DISCS SPECIFICALLY DESIGNED FOR GRINDING. YOU MUST NEVER USE CUTTING DISCS TO GRIND ANY MATERIAL.

- The key to efficient grinding is to control the pressure and surface contact between the grinding disc and the workpiece.
- Flat surfaces are ground at an acute angle, usually 15 to 30 degrees to the workpiece. Too great an angle causes concentration of pressure on a small area which may gouge, or burn the workpiece.
- Allow the disc to reach full speed before grinding.
- Avoid overloading the angle grinder. If it becomes hot when being used, allow it to run for a few minutes under no-load conditions.

SELECTING THE CORRECT GUARD

An open and a closed guard is supplied with the CAG800B.

The “open” guard is for grinding and the “closed” one is for cutting.

The open guard should be used with type 27, 28 and 29 discs as follows;

- Type 27 -Depressed centre grinding wheels
- Type 28 -Depressed centre grinding wheels cone shaped
- Type 29 -Depressed centre semi-flexible wheels

The closed guard should be used with type 1, 41 & 42 discs as follows;

- Type 1 - Straight grinding wheels
- Type 41 - Flat cutting off wheels
- Type 42 - Depressed centre cutting off wheels

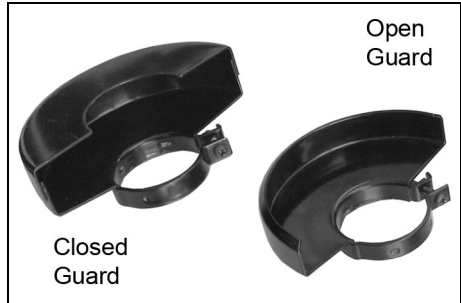

SUITABLE ABRASIVE AND CUTTING DISCS

The following Clarke discs are suitable for use with the CAG800B. Always use the correct disc type and guard for its intended task.

| | Use | Model No | Diameter | Bore | Part No |
|--|--------------------|--------------|----------|------|---------|
| | Cutting & Grinding | PD1 (plasma) | 115mm | 22mm | 3052050 |
| | Metal Cutting | ----- | 115mm | 22mm | 6470775 |
| | Metal Grinding | ----- | 115mm | 22mm | 6470705 |
| | Masonry Cutting | ----- | 115mm | 22mm | 6470735 |

MAINTENANCE

CHANGING THE CARBON BRUSHES

1. The CAG800B is supplied with a replacement pair of carbon brushes for the motor. These may be replaced after extensive use by your Clarke dealer or a suitably qualified technician.
 - Both brushes should be replaced at the same time.

CLEANING

- To maintain the best possible performance from your angle grinder, it must be kept clean.
- To reduce fire hazard, keep the cooling vents free of debris.
- Clean the area around the spindle and mounting washer and keep the threaded locking washer clean.

GENERAL MAINTENANCE

- Make sure that all nuts, bolts and screws are tight and secure.
- Check the secondary handle and the guard for damage.
- Always have any damaged, or worn parts repaired or replaced.
- Always have your angle grinder inspected and maintained by qualified service personnel. Do not attempt to repair the angle grinder unless you are qualified to do so.

SPECIFICATIONS

| Model Number | CAG800B |
|-------------------------------|---|
| Dimensions (L x W x H) | 311 x 130 x 115 mm |
| Weight | 2.4 kg |
| Input Power | 800 W |
| Disc Diameter | 115 mm |
| Disc Bore | 22 mm |
| Spindle Thread Size | M14 |
| No Load Speed | 11000 rpm |
| Sound Pressure Level (LpA dB) | 83.7 dB(A) |
| Sound Power Level (LwA dB) | 94.7 dB(A) |
| Vibration Levels | 10.2 m/s ² (Main Handle) / 11.2 m/s ² (Aux handle. Uncertainty Value (K) =1.5 |

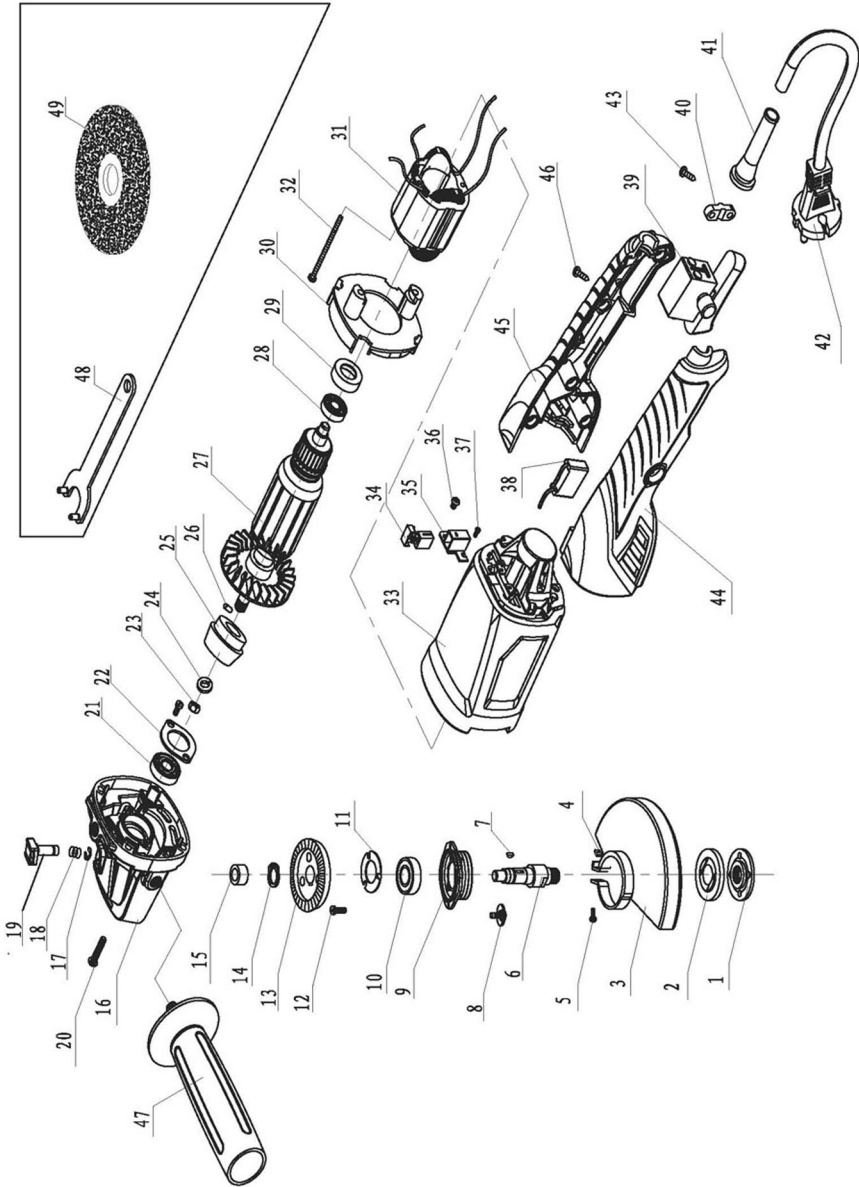

PARTS LIST & DIAGRAM





PARTS LIST & DIAGRAM

| No | Description | No | Description |
|----|-------------------------------|----|--------------------------|
| 1 | Outer Securing Flange | 26 | Round Pin |
| 2 | Inner Securing Flange | 27 | Rotor |
| 3 | Disc Guard | 28 | Bearing 607 |
| 4 | Square Screw | 29 | Bearing Leather Ring 607 |
| 5 | Cross Recess Head Screw | 30 | Air Baffle |
| 6 | Spindle | 31 | Stator |
| 7 | Woodruff Key 3x3.7x10 | 32 | X head ST Screw M4x 65 |
| 8 | Cross Recess Head Screw M4x14 | 33 | Housing |
| 9 | Front Cover | 34 | Carbon Brush |
| 10 | Bearing 6201 | 35 | Carbon Brush Holder |
| 11 | Bearing Platen | 36 | X head ST Screw M3.5x5 |
| 12 | Cross Recess Head Screw M4x10 | 37 | X head ST Screw M3x10 |
| 13 | Large Gear | 38 | Capacitor |
| 14 | Circlip 10 dia | 39 | Switch |
| 15 | Slippery bearing | 40 | Strain Gland |
| 16 | Gearbox | 41 | Cable Sleeve |
| 17 | Split Washer 15 dia | 42 | Cable |
| 18 | Spring for Spindle Lock | 43 | X head ST Screw 4x12 |
| 19 | Spring Lock | 44 | Left Handle |
| 20 | Cross Head s/t screw | 45 | Right Handle |
| 21 | Bearing 608 | 46 | X head ST Screw 4x16 |
| 22 | Bearing Platen | 47 | Auxiliary Handle |
| 23 | M8 Nut | 48 | Spanner |
| 24 | Spring Washer 8mm | 49 | Disc |
| 25 | Small Gear | | |

DECLARATIONS OF CONFORMITY

| | | | | | | | | | | | |
|---|--|---|--|----------------------|---------------------------|------------------|---------|------------------------|-----|----------------|------------|
|  |  <p>Hermil Street, Epping, Essex CM16 4LQ</p> | <p>DECLARATION OF CONFORMITY</p> <p>This is an important document and should be retained.</p> | <p>We hereby declare that this product(s) complies with the following statutory requirement(s):</p> <p><i>Electromagnetic Compatibility Regulations 2016</i> <i>Supply of Machinery (Safety) Regulations 2008</i> <i>The Restriction of the Use of Certain Hazardous Substances in Electrical and Electronic Equipment Regulations 2012</i></p> <p>The following standards have been applied to the product(s):</p> <p>EN 55014-1:2017, EN 55014-2:2015, EN IEC 61000-3-2:2019, EN 61000-3-3:2013 + A1, EN 60745-1:2009 + A11, EN 60745-2-3:2011 + A2 + A11 + A12 + A13, IEC 62321-1:2013, IEC 62321-2:2013, IEC 62321-3-1:2013, IEC 62321-4:2013 + AMD1:2017 CSV, IEC 62321-5:2013, IEC 62321-6:2015, IEC 62321-7-1:2015, IEC 62321-7-2:2017, IEC 62321-8:2017, ISO 17075:2017.</p> <p>The technical documentation required to demonstrate that the product(s) meet(s) the requirement(s) of the aforementioned legislation has been compiled and is available for inspection by the relevant enforcement authorities.</p> <p style="text-align: right;">The UKCA mark was first applied in: 2022</p> | | | | | | | | |
| | | | <table border="0"> <tr> <td style="width: 30%;">Product Description:</td> <td>4.5° Angle Grinder – 800W</td> </tr> <tr> <td>Model number(s):</td> <td>CAG800B</td> </tr> <tr> <td>Serial / batch Number:</td> <td>N/A</td> </tr> <tr> <td>Date of Issue:</td> <td>20/10/2022</td> </tr> </table> <p>Signed:  J.A. Clarke Director</p> | Product Description: | 4.5° Angle Grinder – 800W | Model number(s): | CAG800B | Serial / batch Number: | N/A | Date of Issue: | 20/10/2022 |
| Product Description: | 4.5° Angle Grinder – 800W | | | | | | | | | | |
| Model number(s): | CAG800B | | | | | | | | | | |
| Serial / batch Number: | N/A | | | | | | | | | | |
| Date of Issue: | 20/10/2022 | | | | | | | | | | |
| | | | <p>CAG800B UKCA Clarke DOC 102022</p> <p>Page 1 of 1</p> | | | | | | | | |

| | | | | | | | | | | | |
|---|--|---|---|----------------------|---------------------------|------------------|---------|------------------------|-----|----------------|------------|
|  |  <p>Fitzwilliam Hall, Fitzwilliam Place, Dublin 2</p> | <p>DECLARATION OF CONFORMITY</p> <p>This is an important document and should be retained.</p> | <p>We hereby declare that this product(s) complies with the following directive(s):</p> <p>2014/30/EU <i>Electromagnetic Compatibility Directive</i> 2006/42/EC <i>Machinery Directive</i> 2011/65/EU <i>Restriction of the Use of Certain Hazardous Substances in Electrical & Electronic Equipment (RoHS) Directive</i></p> <p>The following standards have been applied to the product(s):</p> <p>EN 55014-1:2017, EN 55014-2:2015, EN IEC 61000-3-2:2019, EN 61000-3-3:2013 + A1, EN 60745-1:2009 + A11, EN 60745-2-3:2011 + A2 + A11 + A12 + A13, IEC 62321-1:2013, IEC 62321-2:2013, IEC 62321-3-1:2013, IEC 62321-4:2013 + AMD1:2017 CSV, IEC 62321-5:2013, IEC 62321-6:2015, IEC 62321-7-1:2015, IEC 62321-7-2:2017, IEC 62321-8:2017, ISO 17075:2017.</p> <p>The technical documentation required to demonstrate that the product(s) meet(s) the requirement(s) of the aforementioned directive(s) has been compiled and is available for inspection by the relevant enforcement authorities.</p> <p style="text-align: right;">The CE mark was first applied in: 2013</p> | | | | | | | | |
| | | | <table border="0"> <tr> <td style="width: 30%;">Product Description:</td> <td>4.5° Angle Grinder – 800W</td> </tr> <tr> <td>Model number(s):</td> <td>CAG800B</td> </tr> <tr> <td>Serial / batch Number:</td> <td>N/A</td> </tr> <tr> <td>Date of Issue:</td> <td>20/10/2022</td> </tr> </table> <p>Signed:  J.A. Clarke Director</p> | Product Description: | 4.5° Angle Grinder – 800W | Model number(s): | CAG800B | Serial / batch Number: | N/A | Date of Issue: | 20/10/2022 |
| Product Description: | 4.5° Angle Grinder – 800W | | | | | | | | | | |
| Model number(s): | CAG800B | | | | | | | | | | |
| Serial / batch Number: | N/A | | | | | | | | | | |
| Date of Issue: | 20/10/2022 | | | | | | | | | | |
| | | | <p>CAG800B CE Clarke DOC 102022</p> <p>Page 1 of 1</p> | | | | | | | | |

A SELECTION FROM THE VAST RANGE OF

Clarke®

QUALITY PRODUCTS



AIR COMPRESSORS

From DIY to industrial, Plus air tools, spray guns and accessories.

GENERATORS

Prime duty or emergency standby for business, home and leisure.

POWER WASHERS

Hot and cold, electric and engine driven - we have what you need

WELDERS

Mig, Arc, Tig and Spot. From DIY to auto/industrial.

METALWORKING

Drills, grinders and saws for DIY and professional use.

WOODWORKING

Saws, sanders, lathes, mortisers and dust extraction.

HYDRAULICS

Cranes, body repair kits, transmission jacks for all types of workshop use.

WATER PUMPS

Submersible, electric and engine driven for DIY, agriculture and industry.

POWER TOOLS

Angle grinders, cordless drill sets, saws and sanders.

STARTERS/CHARGERS

All sizes for car and commercial use.

PARTS & SERVICE: 0208 988 7400

Parts Enquiries
Parts@clarkeinternational.com

Servicing & Technical Enquiries
Service@clarkeinternational.com

SALES: UK 01992 565333 or Export 00 44 (0)1992 565335

Clarke INTERNATIONAL Hemnall Street, Epping, Essex CM16 4LG
www.clarkeinternational.com